



VIPER XP



TECHNICAL SPECIFICATIONS

QUICK LINKS

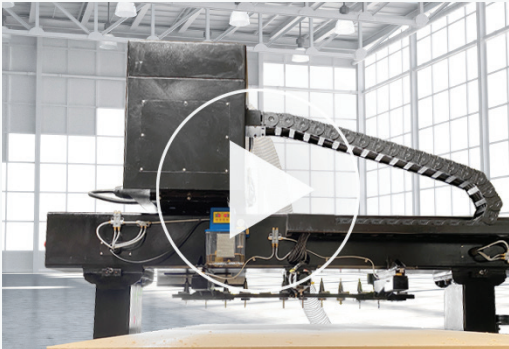

See the VIPER XP in action on Youtube

[SEE IT IN 360° 3D](#)

[SEE FINANCING OPTIONS](#)

[GET A QUOTE](#)

www.CNCfactory.com

[714-581-5999](tel:714-581-5999)

sales@cncfactory.com

5G CNC Inclusions:

- 10HP ATC air-cooled spindle
- Driverless servo system with helical rack & pinion
- No machine homing or calibration
- 8-tool rotary carousel with rapid 8-second tool change
- Driverless mobile control center with 21" touch screen, wireless remote & HD Camera
- Automatic material alignment pins, loading wheels
- Zoned high-flow vacuum table
- Single & dual vacuum ports
- Automatic vacuum communication
- Auto tool length, pressurized lubrication, robotic dust skirt
- Space-saving integrated robotic wiring
- On-board air-conditioning
- 8 ISO-30 tool holders & 1 ISO tool changer
- Pre-wired for Plug & Play add-ons

Support & Warranty

- Lifetime machine support
- 18-month parts and components warranty
- 5-year advanced exchange program
- CNC University training

Pre-installed software option:

KCD
software



FOR PRICING
& ILLUSTRATED
FEATURES
DOWNLOAD
THE FULL
BROCHURE



TECHNICAL SPECS

Speeds	800 inches per minute cutting, 1800 inches per minute rapid movements
Spindle	10HP air-cooled ATC spindle with manual release
Carousel ATC	<ul style="list-style-type: none"> • 8-position ISO-30 servo controlled rotary carousel ride-along ATC tool changer (8 seconds) • Eight (8) ISO ER-30 tool holders and ER wrench included • Auto tool length measurement sensor included
CNC Controller	<ul style="list-style-type: none"> • 5th generation 21" touch screen industrial control center with handheld controller and easy button operation • Syntec electrical control with PC front end • Built-in continuous operation file saving and production override with speed control • G-Code compatible with virtually every CAD and woodworking software. • Tool wear history with built-in alarm stops, USB, WiFi, ethernet, work coordinates and on-screen programming
Cooling	On-board integrated air conditioner
Network Communications	Windows 10 front end with ethernet ready connection and WiFi compatible
Software Installed	KCD Software option. The Viper is compatible with virtually all G-code
Servo System	Yaskawa 5G encoding system with self-adjusting servo operations
Repositioning	Acceleration and deceleration working and repositioning within +/- .001"

FOOTPRINT

Processing Area	Table Size	4' x 8'	4' x 10'	5' x 10'	5' x 12'
	X-Axis Width	49"	49"	61"	61"
	Y-Axis Length	97"	121"	121"	145"
	Z-Axis Height	11.5"	11.5"	11.5"	11.5"
	Z-Axis Clearance	Up to 4" clearance with Gantry mount ATC		Custom size tables and configurations available	
		Up to 9" clearance with rear mount ATC			

Footprint

4' x 8' Table
91" x 122" x 96"H
5200lbs.

5' x 10' Table
104" x 146" x 96"H
5800lbs.

4' x 10' Table
91" x 146" x 96"H
5500lbs.

5' x 12' Table
104" x 170" x 96"H
6300lbs.

4 X 8 FRONT VIEW & SIDE LAYOUT

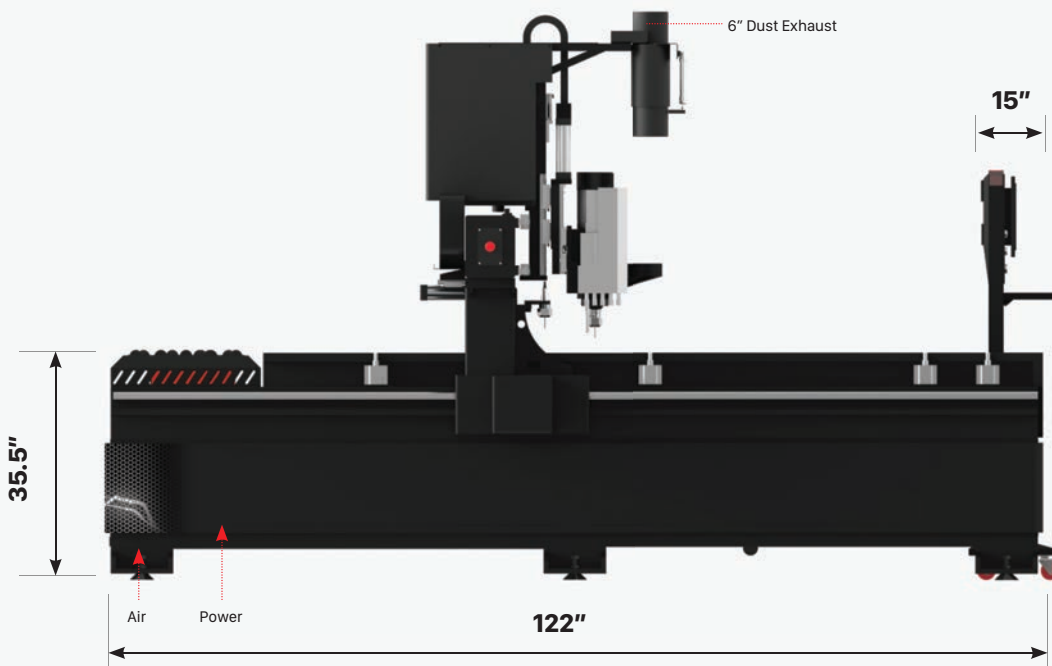
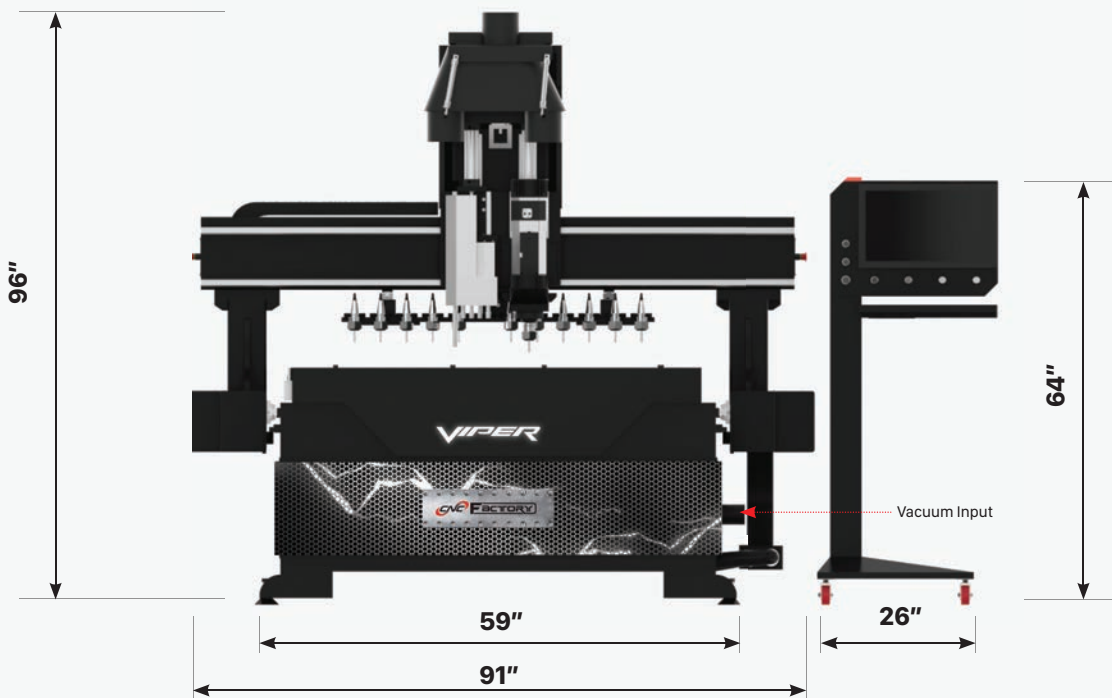

MECHANICAL/ELECTRICAL INSTALLATION

- AC - CNC Machine:**
- 208-240 volts, 3 phase. 30amps.
 - Single phase option available for additional charge.
- AC - Vacuum Pump:**
- 208-240 volts, 3 phase. 50amps.
 - 208-240 volts, single phase. 70amps.
- Air Pressure:** 8 bar, 120 psi, 9 cfm
- Dust Collection:** 2000 cfm for main 6" port

UPGRADE OPTIONS

- Production Upgrades:**
- Custom table size
 - Custom gantry height
 - Single-phase power conversion
 - Horizontal side spindle
 - 4th axis on spindle
 - Aggregate head rotary on spindle
- Plug & Play Upgrades:**
- 12HP ATC spindle
 - 9-Position drill block
 - 12-tool ATC
 - 4-Port marking block
 - V300 Vacuum pump
 - Mister kit
- Tooling:**
- Deluche Vision Marking Tool
 - Cabinet Startup tooling kit
 - Cabinet & drill block tooling kit

INSTALLATION

Installation, when purchased, will be performed by a CNC Factory-trained service technician or Certified Dealer Technician. Installation is to be understood as the assembly of the machine to the "ready to run" state. It does not include floor, masonry work, machine leveling, the running of electrical, pneumatic or dust extraction services to the site. Training will be on the machine operations only. Software training, if any, can be done before or after installation by CNC Factory University training services. Training will be conducted on site by the service technician after installation has been completed.

- Options:**
- 2-day on-site installation and training by certified CNC Factory technician. Flat rate for any location in the continental USA. Inclusive of travel & incidental expenses.
 - Extra training day on top of standard 2-day installation. Must be purchased together with standard 2-day installation.



CNC FACTORY 5G CNC ROUTERS

	<i>VIPER</i>	<i>SIDEWINDER</i>	<i>PYTHON</i>
5th Generation CNC Features			
ATC Air-Cooled Spindle	10HP	12HP	12HP
No Homing or Alignment Servo System	✓	✓	✓
Axis Motor Size (X&Y)	Servo 750W	Servo 750W	Servo 850W
Axis Motor Size (Z)	Servo 1300W	Servo 1300W	Servo 1300W
Driverless Mobile Touch Screen & Remote Controller	✓	✓	✓
Cutting Speed	800 IPM	900 IPM	1000 IPM
Travel Speed	1800 IPM	1800 IPM	2500 IPM
Auto Tool Measuring	✓	✓	✓
ATC Tool Changer Setup	on gantry bar	rotary carousel	rotary carousel
ATC Tool Changer Capacity	8 tools, upgradable to 12	8 tools, upgradable to 12	12 tools
Tool Change Time	8 seconds	8 seconds	8 seconds
5G Helical Rack & Pinion (X & Y axes)	✓	✓	✓
Network, WiFi, USB Connectivity	✓	✓	✓
Onboard Air-conditioning & Cooling	✓	✓	✓
Pressurized Automatic Oil Lubrication	✓	✓	✓
5G Servo System	✓	✓	✓
Compatiblilty with popular CAD/CAM software	✓	✓	✓
Servo Gear Reduction	✓	✓	✓
Intelligent Zoned High-flow Vacuum System	single layer	dual layer	dual layer
Material Position Pins & Guide Rails	✓	✓	✓
Robotic Material Alignment	X	upgradable	✓
Robotic Cleaning & Unloading	X	✓	✓
Robotic Material Sensing for Dust Extraction	X	upgradable	✓
Deluche Vision Marking Tool	sold separately	sold separately	sold separately
V300 Intelligent Vacuum Pump	sold separately	sold separately	sold separately
Robotic Label Printing & Application	X	X	upgradable
Built-in Software & Tool Holders			
KCD (if pre-qualified for KCD 6-month CNC Commander Trial)	✓	✓	✓
VCARVE Pro	✓	✓	✓
ISO-30 Tool Holder	8 Tools	8 Tools	12 Tools
Production Upgrades			
Custom-sized tables	✓	✓	✓
Custom gantry height	✓	✓	✓
Single-phase power conversion	✓	✓	✓
Anytime Upgrades			
Spindle	to 12HP	X	X
9-Position Drill Block	✓	✓	✓
ATC tool	up to 12	up to 12	X
4- Port Marking block	✓	✓	✓
V300 Vacuum Pump	✓	✓	✓
Deluche vision marking tool	✓	✓	✓
Mister	✓	✓	✓
Robotic Material Alignment	X	✓	included
Robotic Loading Arm	X	✓	included
Hydraulic Automated Loading Table	X	✓	included
Unloading Conveyor with Material Sensing	X	✓	included
Robotic Label Printing & Application	X	X	✓
Training			
Lifetime Technical Support	✓	✓	✓
CNC University Certification	✓	✓	✓
On-Site Support	sold separately	sold separately	1 year
Warranty			
Advance Exchange Program on Major Components	5 years	5 years	5 years
Warranty	18 months	18 months	18 months